

**PCFR**  
CLEVER WATER SOLUTIONS

**PoolCop**  
Always. Better. Blue.

**PoolCop Chlorine Sensor  
FAC - Free Available Chlorine  
Installer and User Manual**



**Date:** April 20<sup>th</sup>, 2022

**Manual Version:** 44EN.1

**Firmware Version:** V44

**Compatible with:**

PoolCop Evolution

PoolCop Evolution American Pool

PoolCop Genesis

PoolCop Genesis American Pool



Certified to  
NSF/ANSI Standard 50



## **Change Summary**

January 08 <sup>th</sup> , 2021	Original Issue, NSF 50 and CE Certification
August 06 <sup>th</sup> , 2021	Kit updated to include Isolation Valves
October 04 <sup>th</sup> , 2021	Proof reading
April 20 <sup>th</sup> , 2022	Picture of Modbus adapter

# Contents

<b>Section 1 Introduction</b>	<b>5</b>
1.1 Foreword	5
1.2 Brief Description of FAC	5
1.3 Features and Display of FAC	5
1.4 Certification, Accuracy	5
1.5 Notes, Cautions, Warnings and Definitions	6
1.6 Important Information, Safety Notices and Precautions	7
1.7 Useful Conversions	9
<b>Section 2 Warranty, Records</b>	<b>10</b>
2.1 Chlorine Sensor Warranty Registration Card	10
2.2 Chlorine Sensor Warranty	11
2.3 Chlorine Sensor Maintenance Card	12
<b>Section 3 Chlorine Sensor Installation</b>	<b>13</b>
3.1 General	13
3.2 Acceptable Parameters	15
3.3 Layout and Parts	15
3.4 Pre-Installation Preparation and Inspection	17
3.5 Chlorine Sensor	17
3.6 Commissioning	22
3.7 Completing the Installation	23
3.8 Post Installation Inspection, Documentation, Procedures	24
3.9 Chlorine Sensor Conditioning	24
<b>Section 4 User Guide</b>	<b>25</b>
4.1 PoolCop Chlorine Sensor in Menus	25
4.2 View the Display of FAC	26
4.3 Chlorine Sensor Calibration	27
4.4 View and Reset Alerts	29
<b>Section 5 Programming Guide</b>	<b>30</b>
5.1 Chlorine Sensor Configuration	30
<b>Section 6 Troubleshooting and Maintenance</b>	<b>31</b>
6.1 Troubleshooting	31
6.2 Prefilter Cleaning and Maintenance	33
6.3 Chlorine Sensor Maintenance	34
<b>Section 7 Storage, Decommissioning and Disposal</b>	<b>36</b>
7.1 Winterization and Storage	36
7.2 Disposal	36
<b>Section 8 Spare Parts and Diagrams</b>	<b>37</b>
8.1 Recommended Installation Accessories (not supplied)	37
8.2 Optional Installation Accessories	37
8.3 Spare Parts List	37
<b>Section 9 Technical Specifications</b>	<b>40</b>

## Figures

Figure 1 - Serial Number Location .....	10
Figure 2 – PoolCOP Chlorine Sensor Installation Pack NA.....	16
Figure 3 - Chlorine Sensor Panel, Component Location .....	16
Figure 4 - Chlorine Sensor Flow Direction .....	17
Figure 5 - Sensor Compression Fittings.....	20
Figure 6 - Chlorine Sensor FAC Label.....	20
Figure 7 - Chlorine Sensor and Cable Connectors .....	21
Figure 8 – Chlorine Sensor Cable Connection .....	21
Figure 9 – Modbus Hub sockets on the CCU/DCCU.....	22
Figure 10 - Chlorine Sensor Connectors, LED's .....	22

## Section 1 INTRODUCTION

1.1	Foreword .....	5
1.2	Brief Description of FAC.....	5
1.3	Features and Display of FAC .....	5
1.4	Certification, Accuracy .....	5
1.5	Notes, Cautions, Warnings and Definitions.....	6
1.6	Important Information, Safety Notices and Precautions.....	7
1.7	Useful Conversions.....	9

### 1.1 FOREWORD

We maintain a policy of continuous research and development and therefore reserve the right to make changes and improvements to this manual and any of the Products described.

Any reference in this manual to “the pool owner” refers also to the owner of the Product or Products. The owner may appoint a representative to act on their behalf. The owner retains full and all responsibility for decisions made by and the actions of this representative.

### 1.2 BRIEF DESCRIPTION OF FAC

The sensor is optimized for measurement of swimming pool water disinfection, with and without stabilizer, whether by means of liquid chemical injection, tabular or granular chemical erosion, and/or chlorine electrolysis without disturbance from the by-products generated.

The PoolCOP Chlorine Sensor FAC measurement of total free available chlorine (free chlorine and bound/stabilized chlorine) in swimming pool water (or water of a similar quality), measures independently of the content of combined chlorine (chloramines). This is equivalent to the DPD1 test method.

Stabilizer is used to prevent premature decomposition by sunlight in the disinfection of swimming pool water, particularly in outdoor pools. When cyanuric acid (CyA) is added to the water containing free chlorine (HOCl and OCl) then chlorine bound to organic carrier molecules are created. This is mainly compound derivatives of trichloroisocyanuric acid.

The sensor is a membrane covered, amperometric two-electrode sensor which measures the concentration of total available chlorine in the water. The chlorine compounds dissolved in the water pass through the sensor membrane and are electrochemically transformed on the working electrode. The primary current signal resulting from the transformation can be evaluated to determine the chlorine concentration in parts per million. The integral sensor signal transformer converts the primary sensor current into an output signal using Modbus communication protocol via RS485.

### 1.3 FEATURES AND DISPLAY OF FAC

Measurement of free available chlorine is used for reporting and alerting features.

Primary display of measured FAC is available via the MAINTENANCE menu. It is not displayed on the WELCOME screen display.

Display is also available via the WATER AND TREATMENT configuration menu, and via the web interfaces (if connected).

### 1.4 CERTIFICATION, ACCURACY

The NSF/ANSI 50 certification mark on a water quality testing device (WQTD) used in recreational waters, such as pools and spas, means that the product was reviewed and certified by NSF International to meet applicable American National Standards for product design and performance. NSF tests and re-tests products to confirm that they comply with all requirements of certification for performance, accuracy and operating range. Certification levels of L1, L2, and L3 are possible with L1 being the highest rating. Go to [www.nsf.org](http://www.nsf.org) for more information.

The PoolCOP Chlorine Sensor FAC is certified to NSF 50 WQTD as a Level 1 (L1) Free Chlorine device.

## 1.5 NOTES, CAUTIONS, WARNINGS AND DEFINITIONS

Within this manual some information is highlighted in the form of notes, cautions, warnings, etc. The following definitions apply throughout:



**NOTE**

A step, procedure, technique, etc. which is considered important or essential to emphasize.



**CAUTION**

A step, procedure, technique, etc. which could result in damage to equipment if not carefully followed.



**WARNING**

A step, procedure, or technique which could result in personal injury if not carefully followed.



Certified to NSF/ANSI Standard 50

**NSF/ANSI-50**

A step, procedure, or technique required to comply with NSF/ANSI 50 where required.



Read the installation manual and all warnings in full.  
Follow all instructions.



**WEAR HAND PROTECTION**

Always wear correct chemical resistant hand protection when handling chemicals.



**EYE PROTECTION**

Always wear correct eye protection when handling chemicals.

**May**

An acceptable or suggested means of accomplishment.

**Should**

Normally used to indicate a preferred but non-mandatory method of accomplishment.

**Must, will**

The instructions or procedures are mandatory.

**As installed**

The instructions or procedures depend on the specific model or version of equipment installed.

**If installed**

The instructions or procedures depend on whether the equipment is installed.

**As required**

The instructions, procedures, or requirements are mandatory depending on relevant conditions.

**Verify**

A planned change in an indication, annunciation, or message is observed to occur as expected.  
Check the state or condition prior to proceeding.

## 1.6 IMPORTANT INFORMATION, SAFETY NOTICES AND PRECAUTIONS



### WARNING

**Read the security instructions attentively before any use.  
Instructions given below are all important for your safety.**

PoolCOP is a Product of superior design, engineering and manufacture and should be treated with care. The information contained in this section will help you fulfil the warranty obligations and make use of this Product for many years.

Always respect all norms for electrical, hydraulic, chemical and swimming pool installation and operation. No responsibility will be accepted for installation or use of this Product outside the applicable norms.

For the swimming pool to remain a place of pleasure and user-friendliness, it is necessary to take care of the safety of those who bathe and of the installation standards.

The electric connections must be carried out, according to the applicable norms, by a qualified person.



### WARNING

**Keep the sensor and all associated equipment out of the reach of public and animals.**



### WARNING

**Inappropriate use can cause accidents, bodily injury, fire, electrocution, system failure and flooding.**



### CAUTION

**Do not drop any objects into any openings of the equipment and the associated equipment as this could cause serious damage.**



### CAUTION

**Equipment and the associated equipment must be located in an area protected from the elements.**



### WARNING

**Equipment should not be installed near flammable gas or Products.  
In the event of the escape of gas or dangerous Products, there is risk of fire and explosion.**



### CAUTION

**Do not use harsh chemicals, solvents or detergents to clean the equipment.  
Wipe with a soft cloth, slightly dampened in a mild soap-and-water solution.**



### WARNING

**In case of malfunction or if an anomaly occurs (such as a smell of burning from the unit), disconnect the power supply and contact the installer.**



### CAUTION

**Use only approved replacement parts.  
Unauthorized parts and/or modifications could damage the sensor and will void your warranty.**



### WARNING

**Always mount sensor in a safe area not subject to damage by moving objects.  
Never bury the sensor cable.**



### WARNING

**Never operate a sensor without functional flow protection.**

**WARNING**

Any person using, adjusting, or monitoring the sensor must be at least 18 years of age and be familiar with these instructions and the contents of this manual.

**WARNING**

Always take and record manual water chemistry readings in conformance with Health Department requirements. Although automated controllers are a great aid in maintaining healthy water quality, sensors are not a substitute for manual water testing with a certified and an accurate test kit.

**WARNING**

Always read and become familiar with Material Safety Data Sheets (MSDS) and safe handling instructions for all chemicals used with the sensor.

**CAUTION**

The sensor should not be installed where it is accessible to the public.

**CAUTION**

No unauthorized access. Possible consequences are fatal or serious injury.  
Ensure that there can be no unauthorized access to the unit  
The sensor may only be fitted, installed, serviced and operated by trained personnel.

**CAUTION**

Damage can be caused if the sensor is not transported, shipped and stored in its original packaging.  
Retain the packaging in its entirety including the polystyrene inserts

**CAUTION**

If the sensor is stored for an extended period, return it to PCFR for checking or servicing to ensure safe operation and accuracy.



## 1.7 USEFUL CONVERSIONS

		Temperature														
<b>Centigrade °C</b>	-12	-7	-1	0	4	10	16	21	27	32	38	43	49	54	60	
<b>Fahrenheit °F</b>	10	20	30	32	40	50	60	70	80	90	100	110	120	130	130	

		Pressure														
<b>Bar</b>	0	0.1	0.2	0.3	0.4	0.5	0.6	0.7	0.8	0.9	1.0	1.2	1.4	1.6	1.9	
<b>Psi</b>	0	1.5	2.9	4.4	5.8	7.3	8.7	10.2	11.6	13.1	14.5	17.4	20.3	23.2	27.6	
<b>kPa</b>	0	10	20	30	40	50	60	70	80	90	100	120	140	160	190	

		Volume													
<b>m<sup>3</sup></b>	20	40	60	80	100	120	140	160	180	200	220	240	260		
<b>USG</b>	5300	10600	15800	21100	26400	31700	37000	42300	47600	52800	58100	63400	68700		

		Flow Rate												
<b>m<sup>3</sup>/hr</b>	2	4	6	8	10	12	14	16	18	20	24	28	32	
<b>GPM</b>	9	18	26	35	44	53	62	71	79	88	106	123	141	

		Flow Rate												
<b>ml/h or l/hr</b>	0.3ml	20ml	40ml	60ml	140ml	210ml	320ml	1l	1.5l	3l	6l	12l	24l	
<b>GPD</b>	9	0.13	0.25	0.38	0.89	1.33	2.03	6.34	9.51	19	38	76	152	

## Section 2 WARRANTY, RECORDS

2.1	Chlorine Sensor Warranty Registration Card .....	10
2.2	Chlorine Sensor Warranty .....	11
2.3	Chlorine Sensor Maintenance Card .....	12

### 2.1 CHLORINE SENSOR WARRANTY REGISTRATION CARD

Review the warranty details in the Product manual.  
 Detach or scan this warranty card.  
 Promptly complete and return this warranty registration.  
 If information is incomplete or missing it will result in the Product not being registered.

**PCFR SAS**  
**130 Boulevard du Nord**  
**84160 CUCURON**  
**France**

[www.poolcop.com](http://www.poolcop.com) [contact@poolcop.com](mailto:contact@poolcop.com)

---

**Product:**  PoolCop Chlorine Sensor FAC

---

<b>Brand / Model N°:</b> .....	<b>Name of Installer:</b> .....
<b>Serial Number:</b> .....	<b>Installer's Company:</b> .....
<b>Purchased From:</b> <b>PCFR SAS</b>	<b>Telephone:</b> .....
<b>Date of Purchase:</b> <b>DD / MM / YYYY</b>	<b>Date of Installation:</b> <b>DD / MM / YYYY</b>

---

<b>SURNAME:</b> .....	<b>Address:</b> .....
<b>First Name:</b> .....	<b>City / Town:</b> .....
<b>e-mail:</b> .....	<b>Postal Code:</b> .....
<b>Telephone:</b> .....	<b>Country:</b> .....

---

I would like to receive Product maintenance reminders.  
 I would like to receive Product information and news.

---

**Signature:** \_\_\_\_\_ **Date:** **DD / MM / YYYY**

The serial number is located on the decal on the Chlorine Sensor body.



Figure 1 - Serial Number Location

## 2.2 CHLORINE SENSOR WARRANTY

### Standard Warranty Conditions

Before using the Product, we recommend that you carefully read the user manual in which you will find all the usual precautions.

Return the warranty registration card completed with the serial number to activate the warranty. This warranty applies only if the defective Product is presented within the warranty period, accompanied by the original invoice or receipt (clearly indicating the purchase date, and the model of the device). PCFR reserves the right to refuse warranty service if these documents are not presented or if they are incomplete or illegible. The warranty will not apply if the model name or serial number on the Product has been altered, wiped out, deleted, torn, perforated or made illegible.

The warranty is valid years from the date of delivery (see Conditions). This warranty does not cover consumables or parts with limited lifespan. The warranty is automatically invalidated if the customer does not notify PCFR of the latent defect or the alleged non-compliance within 20 (twenty) days from its discovery. The customer is responsible for proving the date of the discovery.

PCFR is only obliged to repair or replace, free of charge, defective or nonconforming parts, at its discretion, and without the Purchaser being entitled to obtain damages for any cause whatsoever. Original spare parts are available from PCFR. The use of other than genuine parts voids the warranty.

#### Terms:

- The warranty start date is defined as follows:
  - This is the date of commissioning, if the installer returns the warranty registration card (see §2.1).
  - Otherwise, if the registration card is not returned, the billing date of the first-level distributor to the first client will be used.
- If the Product is not installed by the installer or an authorized professional, the warranty is limited to 90 days.
- This Product is covered by the following warranty periods:
  - Chlorine Sensor Panel 2 (two) years, excluding consumables or parts with limited warranty such as tubes, connectors, O-rings, etc.
  - Modbus Adapter electronic card 2 (two) years.
  - Chlorine Sensor Cable 1 (one) year, excluding parts with limited warranty such as ferrules, etc.
  - Chlorine Sensor 1 (one) year, excluding consumables or parts with limited warranty such as O-rings, etc.
  - Chlorine Sensor Membrane Cap, no warranty.
  - Chlorine Sensor Electrolyte, no warranty.
- Every service must be conducted and recorded in the maintenance book by the installer or authorized professional. The service checklist and the maintenance card are detailed in the user manual (a copy of this manual can be provided on request).
- PCFR provides no warranties (express, implied, statutory or otherwise) for the Product, the Product software or the software accompanying the Product, regarding the accuracy of the information provided or suitability for a particular purpose.

#### The warranty does not cover:

- Defects and deterioration of Products due to abnormal conditions of storage, especially in case of an accident of any kind whatsoever, will void the Product warranty. The warranty applies only to Products that have become the property of the Purchaser. It applies only to Products wholly distributed by PCFR. The warranty is automatically voided should the Products be used under conditions for which they were not designed. A design flaw is not a latent defect and customers of PCFR are deemed to have received all the technical information on Products sold. PCFR does not cover damage resulting from wear requiring an adaptation or a special assembly, abnormal or not, of the Product unless it was conducted under PCFR's supervision.
- Viral infections or the use of the Product with software not supplied, or software incorrectly installed.
- Neglect.
- A loss of water tightness following an assembly error, installation error or a lack of attention on a sealing element or its installation.
- Accidents, fire, liquids, chemicals other substances, flooding, vibrations, excessive heat, improper ventilation, power surges, excess or inadequate power supply, radiation, electrostatic discharge including lightning, other forces and external influences.
- Transportation costs and the risks associated with Product replacement or repair.

#### Exclusions and Limitations:

PoolCOP is not responsible for the consequences of action taken in response to a displayed value. The results obtained by the Product are not the responsibility of PCFR, whatever the causes and consequences. It is the Purchaser's responsibility to verify the displayed values and proper functioning.

In the context of this warranty, the PCFR's sole obligation is to repair or replace Products which meet the conditions of this warranty. PCFR is not responsible for any loss or damage relating to Products, to service, to this warranty or any other, including:

- Loss of use of the pool, spa, water body or aquatic venue or facility.
- Financial losses.
- Price paid for the Product.
- Loss of profit revenue, data, enjoyment or use of the Product or associated Products.
- Loss or indirect loss or accidental damage.
- Any direct or indirect prejudice linked to the unavailability of the Product for any duration.

#### Additional Warranty Conditions for USA and North America

Subject to the warranty limitation set forth, PCFR warrants that the Products sold hereunder will substantially conform to PCFR's published specifications and will be free from defects in material and workmanship under normal and proper use and service. Drawings, functional specifications, formal submittals and any other requirements documents prepared by PCFR and approved by the Purchaser shall be deemed the correct interpretations of the work to be performed even if inconsistent with other, conflicting plans and specifications, whether prepared by PCFR, the Purchaser or otherwise. In the event of resale, the Purchaser agrees to extend to its customers no greater warranties and limit its liability and remedies to the same extent as those set forth herein.

**Warranty Limitation.** The warranty and remedies for breach of warranty provided for in these General Conditions extend only to the original end-user's Production use of Products and do not cover, and PCFR shall not be liable for, (i) third-party Products provided/specified by the Purchaser, and any other third-party Products expressly identified as such, are specifically excluded from PCFR's warranty set forth herein. PCFR's sole and exclusive warranty liability, responsibility and obligation with respect to such third-party Product is to use all commercially reasonable efforts to pass through to Purchaser any applicable warranties provided by the PCFRs of such third-party Products, if any, (ii) Products returned contaminated by chemicals or other substance, (iii) abnormal wear and tear or damage caused by installation, maintenance, or use which is improper or contrary to the instructions published by PCFR, (iv) storage of Products in a wet or damp area or unprotected from weather and other job conditions, (v) any cause beyond the control of PCFR, including without limitation conditions caused by movement, settlement or structural defects of the environment in which the Products are installed, fire, wind, hail, flood, lightning or other acts of God, any conditions related to, or caused by, failure to process or inaccurate processing of time-sensitive information and/or mechanisms, intentional acts, accidents, negligence or exposure to harmful chemicals, pollutants or other foreign matter or energy, (vi) repair or damage caused by anyone except personnel authorized by

PCFR, or (vii) any damage to the finish of the Products after they leave PCFR's facility. Items repaired or replaced and designs corrected under warranty are warranted until: (a) the expiration of the original warranty period; or (b) ninety (90) days from the date the Purchaser receives the repaired or replaced item, whichever is later in time. All Product literature is for illustrative purposes only and does not contain a warranty of any kind. PCFR's advice relating to the technical usage of the Products or the intellectual property rights of others, whether provided orally or in writing or through the provision of test results, is given in accordance with PCFR's best knowledge at that time but shall at all times be deemed to be non-binding. Such advice does not relieve the Purchaser from the obligation, and the Purchaser accepts full responsibility, to confirm for himself the suitability of the Products for the intended purpose(s). THE WARRANTY SET FORTH IS STRICTLY LIMITED TO ITS TERMS AND IS IN LIEU OF ALL OTHER WARRANTIES, GUARANTEES, EXPRESS OR IMPLIED, ARISING BY OPERATION OF LAW, COURSE OF DEALING, USAGE OF TRADE OR OTHERWISE, SPECIFICALLY EXCLUDING ANY IMPLIED WARRANTIES OF MERCHANTABILITY OR FITNESS FOR A PARTICULAR PURPOSE.

**Remedy.** The Purchaser's sole and exclusive remedy, and PCFR's only obligation for breach of warranty hereunder, shall be, at PCFR's option in its sole discretion, to repair or replace the defective Product which fails within the applicable Warranty Period, free of charge, provided that the Purchaser promptly notifies PCFR of such failure and, after receipt of prior written authorization from PCFR, returns such Product to the place requested by PCFR, freight prepaid, and thereupon PCFR finds such to be defective, provided that Purchaser (A) promptly notifies PCFR of such failure; (B) properly prepares the Product for service (including without limitation ensuring that the Products to be inspected/serviced are not pressurized, flushing such Products of all substances, and such other preparation as PCFR may reasonably specify); and (C) make such Products available for inspection and/or service by PCFR's designated service provider in a safe work environment (and permit access to such environment) that is appropriate for the work to be performed. PCFR reserves the right to charge the Purchaser for travel and service time for on-site service technicians in the event the Purchaser fails to meet its commitments above. Without limiting the above, PCFR may, at its own cost and expense, decide to uninstall and remove the Product in question to PCFR's designated facility for inspection and/or repair. In such cases, PCFR shall also, at its own expense, return the repaired or replaced Product to the Purchaser's site and install such Product. PCFR's obligations with respect to breach of warranty are strictly limited to repair, or replacement as stated above. Except as may be otherwise specifically agreed in writing in PCFR's quotation or similar written document issued by PCFR, the Purchaser must pay all other costs related to repair or replacement of Product under warranty, including removal, installation or reinstallation costs. PCFR's personnel must be granted access to inspect the Products claimed to be defective at the site of their installation or use.

**Return Authorization.** All returns, whether under warranty or otherwise, are subject to PCFR's required return authorization process. No Products will be accepted for return unless the Purchaser has fulfilled/met all applicable requirements as set forth below: (i) the Purchaser must certify that all Product to be returned to PCFR (whether under warranty or otherwise) is certified "Contaminate-Free". Prior to returning any Product, Purchaser must contact PCFR to obtain PCFR's "Contaminate-Free Certification" form and complete, sign and return such certification form assuring PCFR that Products to be returned are not contaminated with chemical agents. Such Contaminate-Free Certification must accompany returned Product; (ii) Any Product returned, or to be returned, for repair under warranty is subject to PCFR's verification that such return under warranty is (a) within the applicable Warranty Period; and (b) eligible for warranty repair subject to the warranty limitations set forth; (iii) Any Product returned for credit in accordance with the Products or the intellectual property rights of others, whether provided orally or in writing or through the provision of test results, is given in accordance with PCFR's best knowledge at that time, but shall at all times be deemed to be non-binding. Such advice does not relieve the Purchaser from the obligation, and the Purchaser accepts full responsibility, to confirm for himself the suitability of the Products for the intended purpose(s). THE WARRANTY IS STRICTLY LIMITED TO ITS TERMS AND IS IN LIEU OF ALL OTHER WARRANTIES, GUARANTEES, EXPRESS OR IMPLIED, ARISING BY OPERATION OF LAW, COURSE OF DEALING, USAGE OF TRADE OR OTHERWISE, SPECIFICALLY EXCLUDING ANY IMPLIED WARRANTIES OF MERCHANTABILITY OR FITNESS FOR A PARTICULAR PURPOSE.

**Remedy.** the Purchaser's sole and exclusive remedy, and PCFR's only obligation for breach of warranty hereunder, shall be, at PCFR's option in its sole discretion, to (i) repair or replace the defective Product (other than Product sold as systems (or skids)) which fails within the applicable Warranty Period, free of charge, provided that the Purchaser promptly notifies PCFR of such failure and, after receipt of prior written authorization from PCFR, returns such Product to the place requested by PCFR, freight prepaid, and thereupon PCFR finds such to be defective; or (ii) with respect to Products that were sold as systems (or skids), repair or replacement of defective Product which falls within the applicable Warranty Period, free of charge, provided that the Purchaser (A) promptly notifies PCFR of such failure; (B) properly prepares the Product for service (including without limitation ensuring that the Products to be inspected/serviced are not pressurized, flushing such Products of all substances, and such other preparation as PCFR may reasonably specify); and (C) make such Products available for inspection and/or service by PCFR's designated service provider in a safe work environment (and permit access to such environment) that is appropriate for the work to be performed. PCFR reserves the right to charge the Purchaser for travel and service time for on-site service technicians in the event the Purchaser fails to meet its commitments above. Without limiting the above, PCFR may, at its own cost and expense, decide to uninstall and remove the Product in question to PCFR's designated facility for inspection and/or repair. In such cases, PCFR shall also, at its own expense, return the repaired or replaced Product to the Purchaser's site and install such Product. PCFR's obligations with respect to breach of warranty are strictly limited to repair, or replacement as stated above. Except as may be otherwise specifically agreed in writing in PCFR's quotation or similar written document issued by PCFR, the Purchaser must pay all other costs related to repair or replacement of Product under warranty, including removal, installation or reinstallation costs. PCFR's personnel must be granted access to inspect the Products claimed to be defective at the site of their installation or use.

**Disclaimer; Limitation of Liability, Time for Claims.** The Purchaser agrees that PCFR shall not be liable for INCIDENTAL, SPECIAL, INDIRECT OR CONSEQUENTIAL OR OTHER SIMILAR DAMAGES including but not limited to loss of profit or revenues, damage for loss of use of the Products, damage to property, claims of third parties, including personal injury or death on account of use of the Products or failure of PCFR to warn against or instruct on, or adequately warn against or instruct on, the dangers of the Products or the safe and proper use of the Products, whether or not PCFR has been advised of the potential for such damages. PCFR's total liability hereunder from any cause whatsoever (except liability from personal injury caused by PCFR's negligence), whether arising under contract, warranty, tort (including negligence), strict liability, Products liability or any other theory of liability, will be limited to the lesser of the Purchaser's actual damages or the price paid to PCFR for the Products that are the subject of the Purchaser's claim. All claims against PCFR must be brought within one year after the cause of action arises, and the Purchaser expressly waives any longer statute of limitations.

### 2.3 CHLORINE SENSOR MAINTENANCE CARD

Chlorine Sensor Maintenance Card	Date Due	Date Carried Out	By:	Notes:
<b>Installation</b>	-	/ /		
<b>Initial Calibration</b> <small>After at least 12 preferable 24 hours operation.</small>	-	/ /		Weekly calibration check required. Calibrate after every service *
<b>1<sup>st</sup> Service (+6 months) *</b> <input type="checkbox"/> Replace Membrane Cap <input type="checkbox"/> Replace Electrolyte <input type="checkbox"/> Check Leaks and Air Suction <input type="checkbox"/> Calibrate after 12-24 hours	/ /	/ /		
<b>2<sup>nd</sup> Service (+12 months)*</b> <input type="checkbox"/> Replace Membrane Cap <input type="checkbox"/> Replace Electrolyte <input type="checkbox"/> Check Leaks and Air Suction <input type="checkbox"/> Calibrate after 12-24 hours	/ /	/ /		
<b>3<sup>rd</sup> Service (+18 months)*</b> <input type="checkbox"/> Replace Membrane Cap <input type="checkbox"/> Replace Electrolyte <input type="checkbox"/> Check Leaks and Air Suction <input type="checkbox"/> Calibrate after 12-24 hours	/ /	/ /		
<b>4<sup>th</sup> Service (+24 months)*</b> <input type="checkbox"/> Replace Membrane Cap <input type="checkbox"/> Replace Electrolyte <input type="checkbox"/> Check Leaks and Air Suction <input type="checkbox"/> Calibrate after 12-24 hours	/ /	/ /		
<b>5<sup>th</sup> Service (+30 months)*</b> <input type="checkbox"/> Replace Membrane Cap <input type="checkbox"/> Replace Electrolyte <input type="checkbox"/> Check Leaks and Air Suction <input type="checkbox"/> Calibrate after 12-24 hours	/ /	/ /		
<b>6<sup>th</sup> Service (+36 months)*</b> <input type="checkbox"/> Replace Membrane Cap <input type="checkbox"/> Replace Electrolyte <input type="checkbox"/> Check Leaks and Air Suction <input type="checkbox"/> Calibrate after 12-24 hours	/ /	/ /		
<b>7<sup>th</sup> Service (+42 months)*</b> <input type="checkbox"/> Replace Membrane Cap <input type="checkbox"/> Replace Electrolyte <input type="checkbox"/> Check Leaks and Air Suction <input type="checkbox"/> Calibrate after 12-24 hours	/ /	/ /		
<b>8<sup>th</sup> Service (+48 months)*</b> <input type="checkbox"/> Replace Membrane Cap <input type="checkbox"/> Replace Electrolyte <input type="checkbox"/> Check Leaks and Air Suction <input type="checkbox"/> Calibrate after 12-24 hours	/ /	/ /		

\* Calibration required after every service, after at least 12, preferable 24 hours, operation.  
 The Chlorine Sensor is guaranteed for 1 year provided that all warranty conditions are met.

## Section 3 CHLORINE SENSOR INSTALLATION

3.1	General.....	13
3.2	Acceptable Parameters.....	15
3.2.1	General Condition.....	15
3.2.2	Required Water Parameters.....	15
3.3	Layout and Parts.....	15
3.4	Pre-Installation Preparation and Inspection.....	17
3.5	Chlorine Sensor.....	17
3.5.1	Hydraulic Installation.....	17
3.5.2	Chlorine Sensor Assembly and Preparation.....	18
3.5.3	Install the Sensor in the Sensor Chamber in the Flow Panel.....	19
3.5.4	Chlorine Sensor Cable and Wiring.....	21
3.6	Commissioning.....	22
3.7	Completing the Installation.....	23
3.8	Post Installation Inspection, Documentation, Procedures.....	24
3.8.1	Post Installation Inspection.....	24
3.8.2	Post Installation Documentation.....	24
3.8.3	Post Installation Procedures.....	24

### 3.1 GENERAL

- Installation of the equipment will be done only by qualified and experienced installers.
- Failure to correctly install the equipment according to this manual will void the warranty.
- This installation manual is intended to be used as a checklist; check the boxes next to installation steps ensuring that all steps are completed in the correct sequence.



**CAUTION**  
Only push in to or pull out the sensor slowly from the Sensor Chamber to avoid membrane damaged.



**CAUTION**  
Always keep the sensor moist after commissioning.  
Never allow the flow gauge to run dry.



**CAUTION**  
Do not allow the flow to fall below the minimum flow rate.



**CAUTION**  
Avoid sensor exposure or contact to oils and greasy substances.  
The sensor will no longer measure accurately.  
Replace the membrane cap with a new membrane cap or send the sensor to PCFR for repair.



**CAUTION**  
Avoid touching the electrodes at the bottom of the electrode shaft as they can be damaged.



**CAUTION**  
Avoid touching the membrane part of the Membrane Cap as it can be damaged.



**CAUTION**  
Never re-use a Membrane Cap.



**CAUTION**  
When fitting the filled Membrane Cap to the sensor,  
avoid your fingers blocking the vent hole beneath the transparent rubber band.



**NOTE:**  
Electrolyte is safe. Excess and spills can be safely poured down the drain.



**CAUTION**

**Care for Electrolyte:**

- The electrolyte is sensitive to oxidation.
- Always keep electrolyte bottle sealed after use.
- Do not decant electrolytes into other containers.
- Do not store electrolyte beyond its "Use by" date.
- Store the bottle upside-down so that it can be used free of bubbles as far as possible.



**CAUTION**  
As far as is possible, fill the electrolyte so that it is free from bubbles. Small air bubbles are not a problem, larger air bubbles rise to the upper edge of the membrane cap.



**CAUTION**  
Avoid installations that allow air bubbles to form in the Sensor Chamber.  
Air bubbles adhering to the sensor membrane will cause the sensor to underread.



**CAUTION**  
Only install the sensor in the PoolCOP Chlorine Sensor Panel.  
No assurance of accuracy, warranty or support will be provided if any other installation is used.



**CAUTION**  
Observe the instructions and safety information contained in the operating instructions for equipment.



**CAUTION**  
Install the equipment in a dry location, be protected from rain, frost,  
direct sunlight, splashing water or chemicals.



**CAUTION**  
The ambient temperature must be between 0 and 50°C without condensation



**CAUTION**  
Choose an installation site without vibration, on a clean, rigid and undistorted support.

**CAUTION**

There must be a free outlet or at most a pressure of 1 bar at the outlet of the flow gauge.  
The maximum operating pressure of the respective components must be observed.

**CAUTION**

The sensor's power supply shall not be interrupted.  
Following interruptions to the power supply greater than 2 hours,  
recondition and then recalibrate the sensor.

**NOTE**

Only use the sensor to determine the concentration of free chlorine or chlorine bound to cyanuric acid  
in swimming pool water or water of a similar quality.

## 3.2 ACCEPTABLE PARAMETERS

### 3.2.1 General Condition

- There is no debris in the pool.
- Pool water is acceptably clean.
- Condition of the filter, and the filter media.
- Skimmer and pump pre-filter baskets are clear of debris.
- No recent manual chemical additions to the water, not in the previous 24 hours.
- No tablets or chemical dosing in the skimmers, overflow or balance/buffer tank/s.
- No unusual amounts of oils, suntan lotions, flocculants or surfactants in the water.
- Ensure that the filter media is properly maintained and cleaned as per the manufacturer's instructions and code requirements.
- Check that water level is correct, and that there have been no recent unusual water additions.
- No unusual bather or weather loads in the previous 24 hours.
- No deck or equipment cleaning with non-NSF 50 or NSF 61 certified Products in the last 7 days at least.
- Water body correctly earthed, and resistance tested less than 20 Ω.

### 3.2.2 Required Water Parameters

- TAC 80 to 250 PPM (respect applicable code).
- pH 7.2 to 7.8 (respect applicable code).
- FAC 2 to 10 PPM (respect applicable code).
- CC 0 to 0.4 PPM not to exceed 10% of FC in ppm (respect applicable code).
- CyA 0 to 20 PPM (respect applicable code).
- Flow Rate:
  - Minimum: 20 l/h (0.09 GPM).
  - Optimum: 30 l/h (0.13 GPM) flow rate is optimum when the Flow Indicator lines up with the Flow Mark.
  - Maximum: 100 l/h (0.44 GPM).
- Pressure
  - Maximum: 1.0 bar (14.5 psi) free flow.
  - Minimum: No negative pressure, check that water comes out the inline sample port to verify no suction.
- Temperature
  - Range: 5 to 45°C temperature-compensated (40 to 113°F).
  - Rate: Avoid temperature change exceeding 5°C (8.5°F) in the preceding 60 minutes.
- Cross-sensitivity, the following can lead to measurement errors:
  - Chloramines
  - Bromine
  - Iodine
  - Ozone
  - Chlorine dioxide
  - Other oxidants

## 3.3 LAYOUT AND PARTS

The PoolCop Chlorine Sensor Installation Pack is shipped with:

- PoolCop Chlorine Sensor.
- PoolCop Chlorine Sensor Cable.
- PoolCop Modbus Adapter.



- PoolCOP Chlorine Sensor Panel:
  - Prefilter INLET 3/8" compression connector.
  - Prefilter with washable Prefilter Cartridge.
  - Flow Cell (with flow control, inline sample port with tap, and sensor chamber).
  - Flow Cell OUTLET 3/8" compression connector.
  - 2 x isolation valves, 3/8" tube compression connectors with 3/8" NPTF male thread.
- PoolCOP Chlorine Sensor Maintenance Kit:
  - 1 x Bottle of Electrolyte Gel 50ml, and filling nozzle.
  - 2 x Membrane Caps, with transport cap.

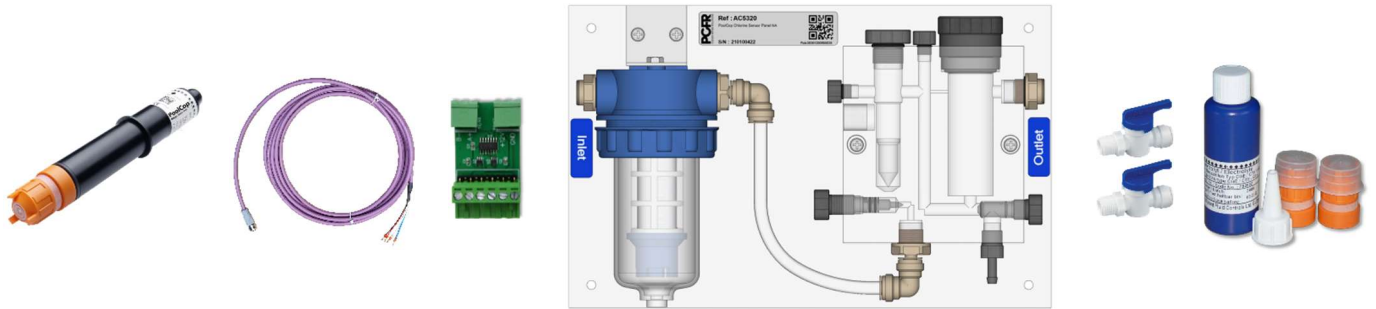

Figure 2 – PoolCOP Chlorine Sensor Installation Pack NA

Not supplied:

- 3/8" tubing to INLET from hydraulic circuit.
- 3/8" tubing from OUTLET and return to the hydraulic circuit.
- 3/8" NPTF female thread cutting tool (if used).
- PVC saddle clamps with 3/8" NPTF female thread (if used).

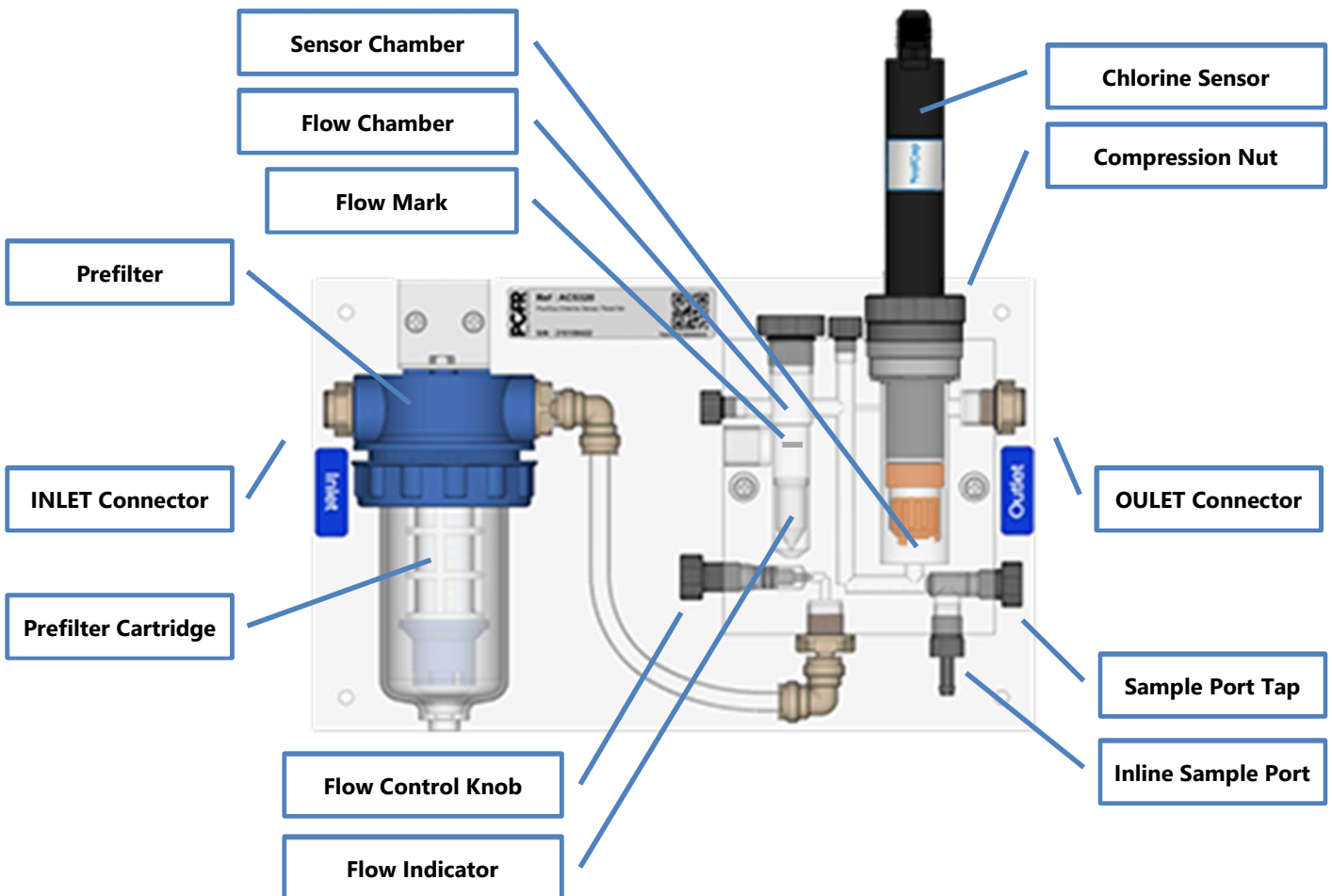

Figure 3 - Chlorine Sensor Panel, Component Location



### 3.4 PRE-INSTALLATION PREPARATION AND INSPECTION

A properly installed and maintained PoolCOP Evolution or PoolCOP Genesis with properly maintained and calibrated pH and ORP measurement is required.

Before commencing installation, the installer should confirm the following with the pool owner:

- Preferred locations for the Chlorine Sensor Flow Panel:
  - The cable is 5m long, install such that the cable and connectors are not stressed or sharply bent at the sensor or CCU/DCCU.
  - The sensor and flow panel essentially vertically and level.
  - In a location:
    - Not exposed to excessive dust.
    - Not exposed to jets of water.
    - Not exposed to weather.
    - Away from the possibility of tampering by unauthorized persons.

When ready to commence the installation, the installer must:

- Disconnect all electrical power to the pool and systems.
- Close all valves, and if necessary, block all inlets to and outlets from the pool.
- Open the CCU/DCCU cover:
  - A flat screwdriver is needed to release the 4 clips.
  - Use a T5 Tamperproof Torx to loosen the 4 screws.

Read 1.6 "Important Information, Safety Notices and Precautions" before starting electrical connection. The installation must comply to all local, state, province and country legislation and code.

The sensor cable must pass through the appropriate compression gland size according to their diameter and the compression gland must be tightened to the recommended setting to secure the cable.

### 3.5 CHLORINE SENSOR

#### 3.5.1 Hydraulic Installation

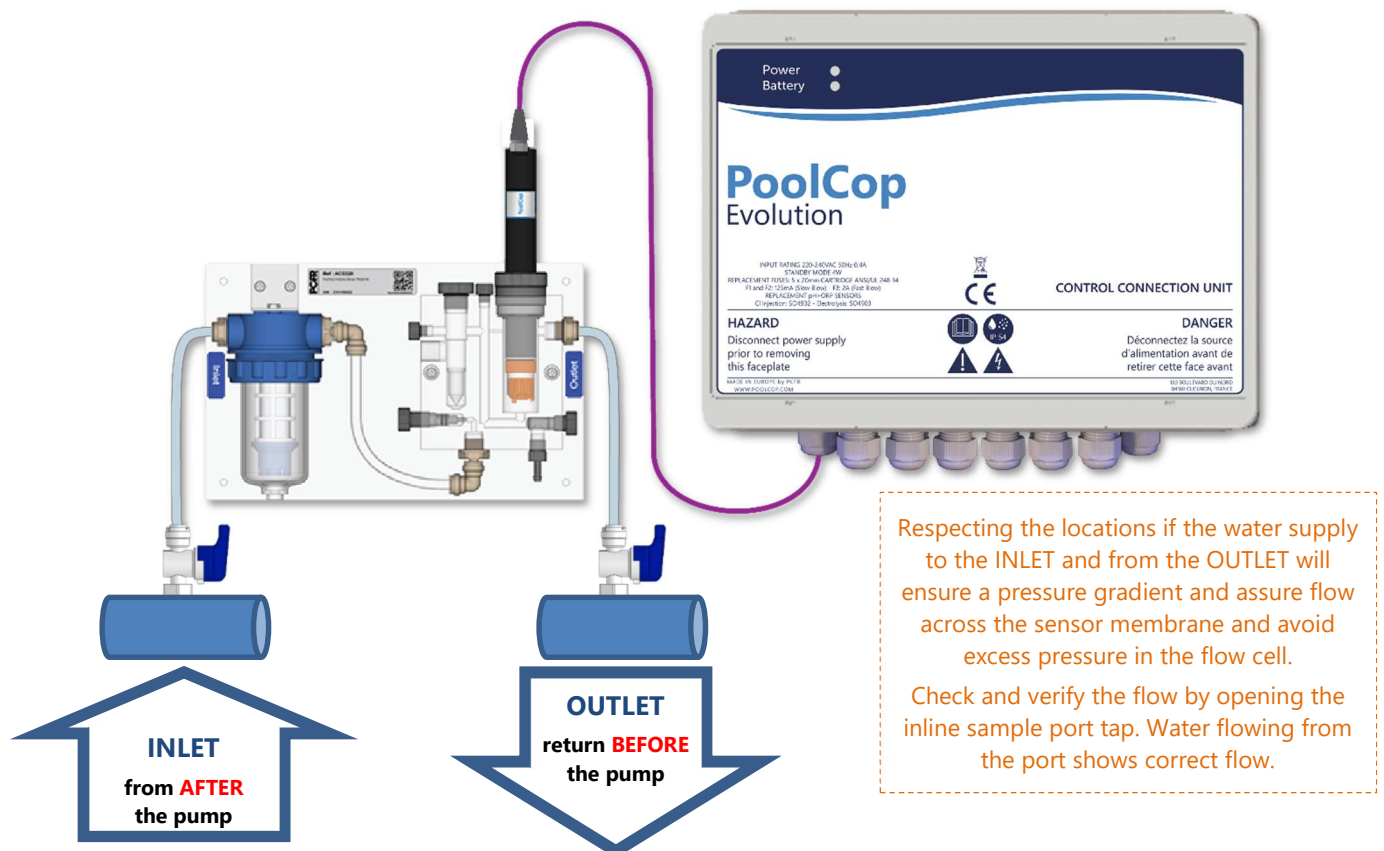

Figure 4 - Chlorine Sensor Flow Direction

To install the Panel:

- Stop pump and all hydraulic power sources.
- Use the 6mm panel drill holes to securely fix the panel to a suitable vertical surface using suitable fasteners for the mounting surface.
- The panel must be installed:
  - o Vertically
  - o Essentially horizontal
- The sensor Panel must be mounted in bypass, and offline from main flow stream:
  - o Inlet water will be taken from a relatively "higher" pressure point:
    - AFTER the filtration pump
    - Just PRIOR to a valve slightly restricted if required
    - Install the 3/8" inlet isolation valve directly on the main pipe tie-in.
    - Use the suitable length of 3/8" tube to connect the isolation valve to the panel inlet (tube radius > 2").
  - o Outlet return water will be to a relatively "lower" pressure point:
    - Just PRIOR to the pump
    - Drain to balance/buffer tank
    - Install the 3/8" outlet isolation valve directly on the main pipe tie-in.
    - Use the suitable length of 3/8" tube to connect the isolation valve to the panel outlet (tube radius > 2").
- Make sure piping, collars, threaded compression fitting and all other fittings are correctly and securely tightened.
- Check that water is flowing correctly through the panel by taking a sample from the water sample tap
- Check that adequate flow is available by ensuring the Flow Indicator moves up when the Flow Control Knob is adjusted open.

### 3.5.2 Chlorine Sensor Assembly and Preparation

#### NOTE

The following videos show clearly how to fill the Electrolyte and clean the sensor.



Changing Electrolyte Gel in English

- [www.youtube.com/watch?v=00a2gkciqdo](http://www.youtube.com/watch?v=00a2gkciqdo)
- [www.youtube.com/watch?v=nUy1BNCqBrE](http://www.youtube.com/watch?v=nUy1BNCqBrE)

Changement de membrane en français :

- [www.youtube.com/watch?v=27H-Q3Mw4Y&t=40s](http://www.youtube.com/watch?v=27H-Q3Mw4Y&t=40s)

- Check the Electrolyte "Unopened Use By" date.

- Remove the cap from the bottle of Electrolyte Gel.
- Screw the nozzle onto the bottle of Electrolyte Gel.
- Press out excess air from the bottle.
- Fill the Membrane Cap with Electrolyte Gel.

- Place the nozzle completely into the Membrane Cap and allow the electrolyte to slowly stream into the cap, while at the same time retracting the nozzle.
- When filling avoiding bubbles as much as possible.
- Fill the Membrane Cap with gel to the level shown, and when the gel reaches the bottom thread.

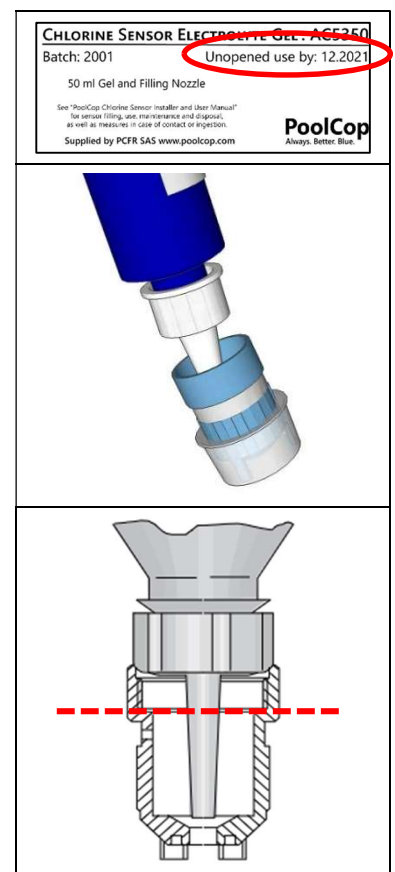

- Place the electrode shaft vertically into the filled Membrane Cap.
- Thread the filled Membrane Cap onto the Sensor body.

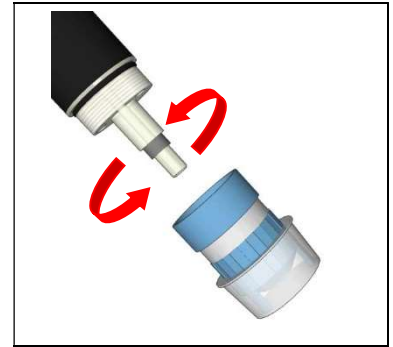

- While screwing on the Membrane Cap, allow excess gel to escape through the air vent hole underneath pressure relief band.
- Screw the cap so that there is no gap between the cap and the sensor body.
- Wipe up any escaped electrolyte with a soft paper towel.
- Rinse the nozzle through thoroughly with clean, warm water, ensuring that there is no electrolyte remaining in the nozzle.

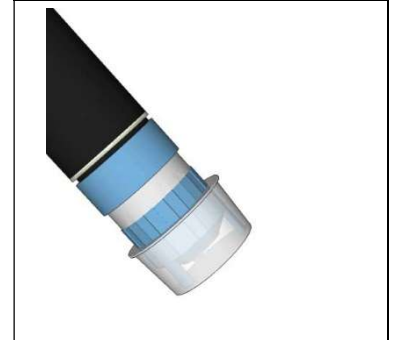

- Remove the transport cap.
- The sensor is now ready to fit to the Sensor Chamber in the Panel

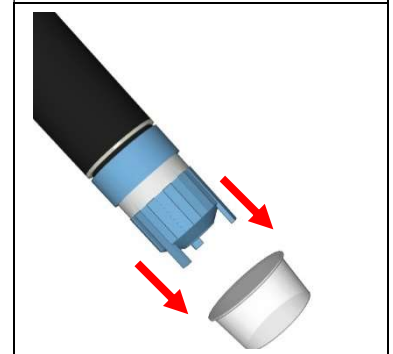

### 3.5.3 Install the Sensor in the Sensor Chamber in the Flow Panel



#### CAUTION

Only push in or pull out the sensor slowly to or from the sensor chamber in the panel to avoid damaging the membrane.



#### CAUTION

Do not allow the membrane to touch the panel structure or parts



#### CAUTION

Always keep the sensor moist after commissioning, never allow the flow gauge to run dry!



#### CAUTION

Do not allow the flow to fall below the minimum flow rate. Monitor the flow of the connected controller. If the measured value is used for control, switch off the control if the flow falls below the minimum flow rate and/or switch to basic load



#### CAUTION

Only install the sensor in PoolCOP Chlorine Sensor Panel to assure flow requirements. No assurance can be provided if other probe housings are used.



**CAUTION**  
 Avoid installations that allow air bubbles to form in the sample water. Air bubbles on the sensor membrane will result in too low a measured value.



**CAUTION**  
 Observe all instructions and safety information in the operating instructions for the PoolCop Chlorine Sensor Flow Panel

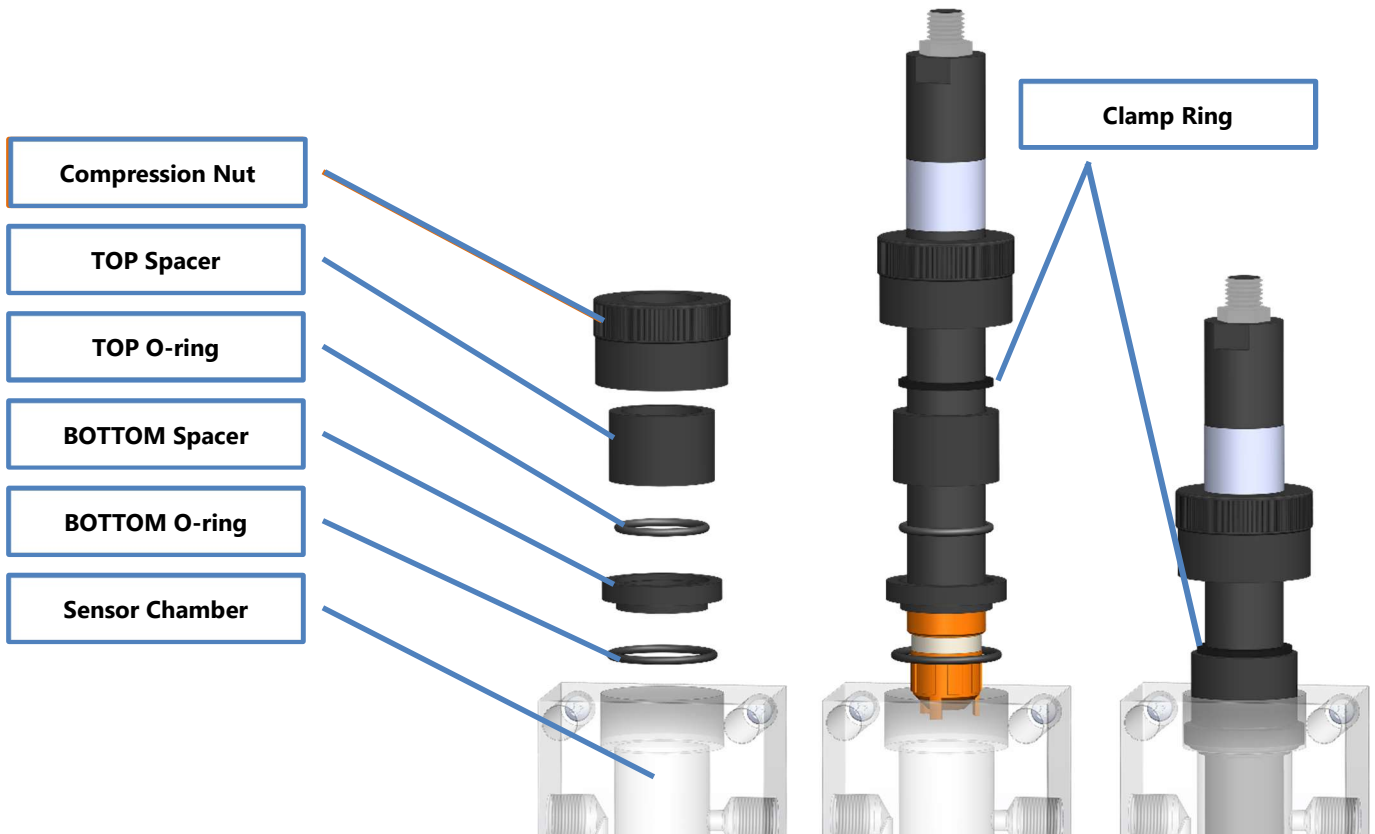

Figure 5 - Sensor Compression Fittings

- Fit the Compression Nut to the sensor from the top, ABOVE the Clamp Ring.
- Fit the following to the sensor from the bottom, BELOW the Clamp Ring:
  - TOP Spacer
  - TOP O-ring
  - BOTTOM Spacer
  - BOTTOM O-Ring
- Insert the sensor into the sensor chamber, ensuring the O-rings are correctly in place.
- The correct insertion depth of the sensor is defined by the Clamp Ring.
- Thread the assembly into the sensor chamber with a light downward pressure.
- Adjust the sensor orientation so that both LED light “windows” in the sensor label are easily visible.

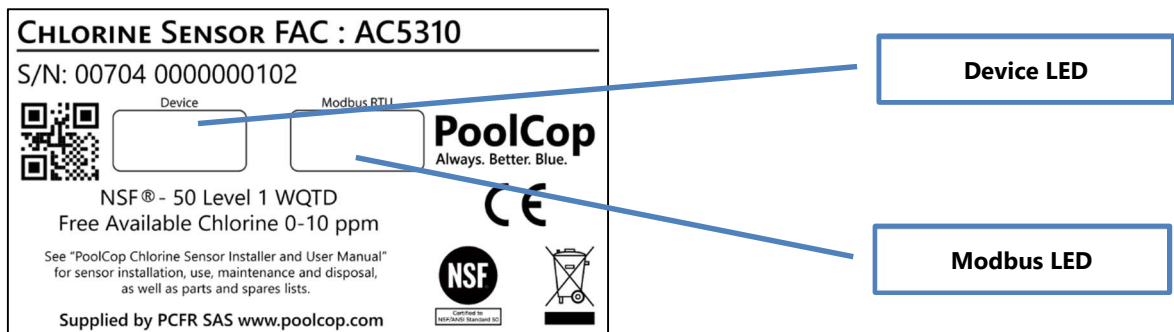

Figure 6 - Chlorine Sensor FAC Label

- Tighten the Compression Nut so that the O-rings make a water- and air-tight seal .



**CAUTION**  
**Only finger-tighten the threaded Compression Nut.**  
**Do not use a tool to tighten.**

### 3.5.4 Chlorine Sensor Cable and Wiring

The sensor communicates via the Modbus communication protocol on the RS485 communication standard.

The required Cable and Modbus Adaptor are supplied with the Installation Pack.

The cable has a threaded connector plug on the sensor end.



Figure 7 - Chlorine Sensor and Cable Connectors



**CAUTION**  
**The sensor will not function correctly if the wires are connected incorrectly and may be damaged.**

To establish communication:

- Switch the CCU/DCCU OFF and disconnect electrical power to CCU/DCCU.
- Open the CCU/DCCU.

#### 3.5.4.1 Connection without Modbus Hub

- Route the sensor cable through a PG9 compression gland. If possible, use an entry on the left side of the enclosure.
- Plug the "power" and "data" 2 pins connectors onto the PoolCop Modbus Adapter, ensuring that the screws are securely tightened:
  - o Connect sensor for power:
    - **GND** to the **BLACK** wire.
    - **+12V** to the **RED** wire.
  - o Connect sensor for data:
    - **A (+)** on **WHITE** wire.
    - **B (-)** on **BLUE** wire.
- Plug the PoolCop Modbus Adaptor into J21 inside the CCU/DCCU.

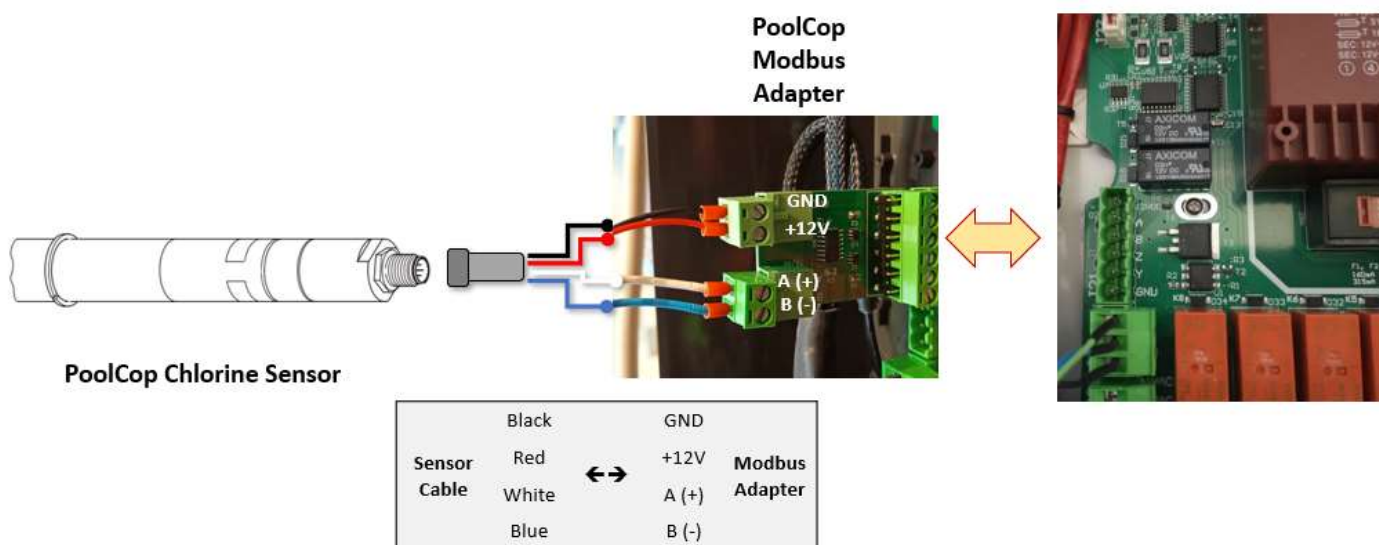

Figure 8 – Chlorine Sensor Cable Connection

- Tighten the PG9 compression gland to ensure cable and connector strain relief.

### 3.5.4.2 Connection with Modbus Hub

- Modbus Hub presence can be recognized by the 4 bases on the CCU/DCCU.



Figure 9 – Modbus Hub sockets on the CCU/DCCU

- The Modbus Hub makes the wiring of Modbus obsolete.
- You only have to plug the connector into **the rightmost socket of the Modbus Hub**.
- Make sure unused headers are fitted with a cap.

### 3.5.4.3 Sensor connection

- Remove the protective rubber cap from the top of the sensor.
- Connect the cable connector to the top of the sensor securely.

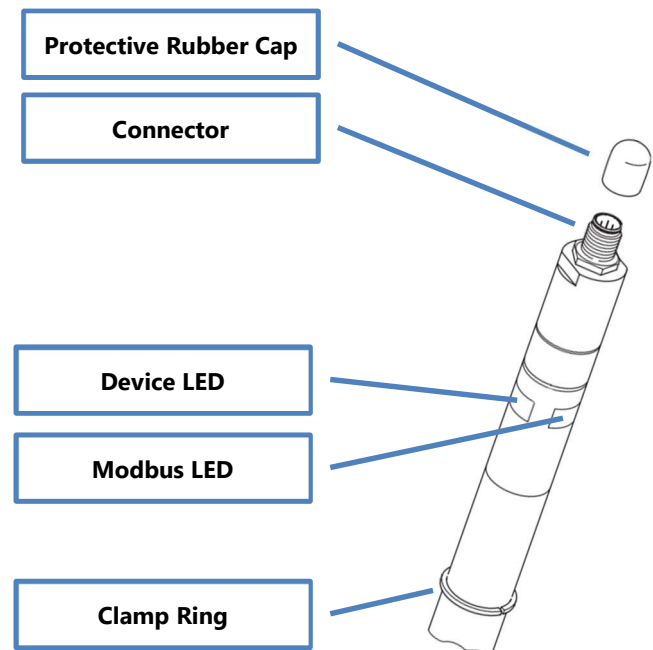

Figure 10 - Chlorine Sensor Connectors, LED's

- Close the CCU/DCCU and reconnect electrical power to CCU/DCCU.

## 3.6 COMMISSIONING

Chlorine Sensor will only start to display Chlorine value after proper configuration.

- Switch the CCU/DCCU **ON**.
- Open all appropriate valves and remove any plugs in the filtration system.
- Switch the filtration pump **ON**.
- Check the chlorine sensor LED lights:
  - After approximately 120 seconds, both LED lights on the sensor should be GREEN and not flashing.
  - If after 120 seconds there are no LED lights illuminated, or the LED lights are not both GREEN and/or if any LED is flashing, see troubleshooting.
- With the pump and filtration running, carefully check for leaks or air suction, especially in the following places:
  - All tubing
  - Flow Panel and Chlorine Sensor.
  - All valves and pipe connectors.



#### CAUTION

**If leaks or air suction are found, switch OFF the CCU/DCCU.  
Repair all leaks or air suction and repeat the procedure, if required.**

- Restore normal operation and water circulation at nominal flow.
- Use the flow control knob to adjust flow to the required value in Acceptable Parameters. The mark traced on the flow chamber indicates the correct rate.

**CAUTION**

Ensure correct flow to ensure correct measurement.

- Secure the CCU/DCCU with 4 tamper proof screws.

### 3.7 COMPLETING THE INSTALLATION

---

Verify that all wiring has been done according to applicable electrical norms.

## 3.8 POST INSTALLATION INSPECTION, DOCUMENTATION, PROCEDURES

---

### 3.8.1 Post Installation Inspection

- Verify that all the wiring is neat and safe.
- With the system running, verify no water leaks or air suction.
- Verify that the water balance and chemistry is in the acceptable range.

### 3.8.2 Post Installation Documentation

Complete the Product warranty registration card.

### 3.8.3 Post Installation Procedures

Ensure that the client has a general knowledge of the installation, understands the functions of the sensor and alerts:

- Introduce system and point out main components and their functions.
- Explain basic system operation, using the User Guide.
- Remind the owner that events outside of the norm may require intervention for water balance and chemistry.
- Explain the water treatment options as installed, including the verification of consumables.
- Hand over completed User Guide.

## 3.9 CHLORINE SENSOR CONDITIONING

---

Before conditioning, ensure that all Acceptable Parameters are respected (•)

The Chlorine Sensor requires conditioning prior to generating stable values:

- For new Chlorine Sensors, install and connect the Chlorine Sensor and run under flow and powered for at least 12 hours preferably 24 hours before calibration.
- After Membrane Cap and/or Electrolyte Gel replacement, run the Chlorine Sensor under flow and powered for at least 12 hours preferably 24 hours before calibration.
- If the Chlorine Sensor is un-powered for two hours or more, connect the Chlorine Sensor and run under flow and powered for at least 12 hours preferably 24 hours before calibration.
- If the Chlorine Sensor is out of water flow will be off for one hour or less, run the Chlorine Sensor under flow and powered for at least one hour prior to use to recondition.



## Section 4 USER GUIDE

4.1	PoolCop Chlorine Sensor in Menus .....	25
4.1.1	Water and Treatment .....	26
4.1.2	Maintenance.....	26
4.2	View the Display of FAC.....	26
4.3	Chlorine Sensor Calibration.....	27
4.3.1	Water Sample for Calibration .....	27
4.3.2	Water Sample Location.....	27
4.3.3	Calibration Procedure.....	28

### 4.1 POOLCOP CHLORINE SENSOR IN MENUS

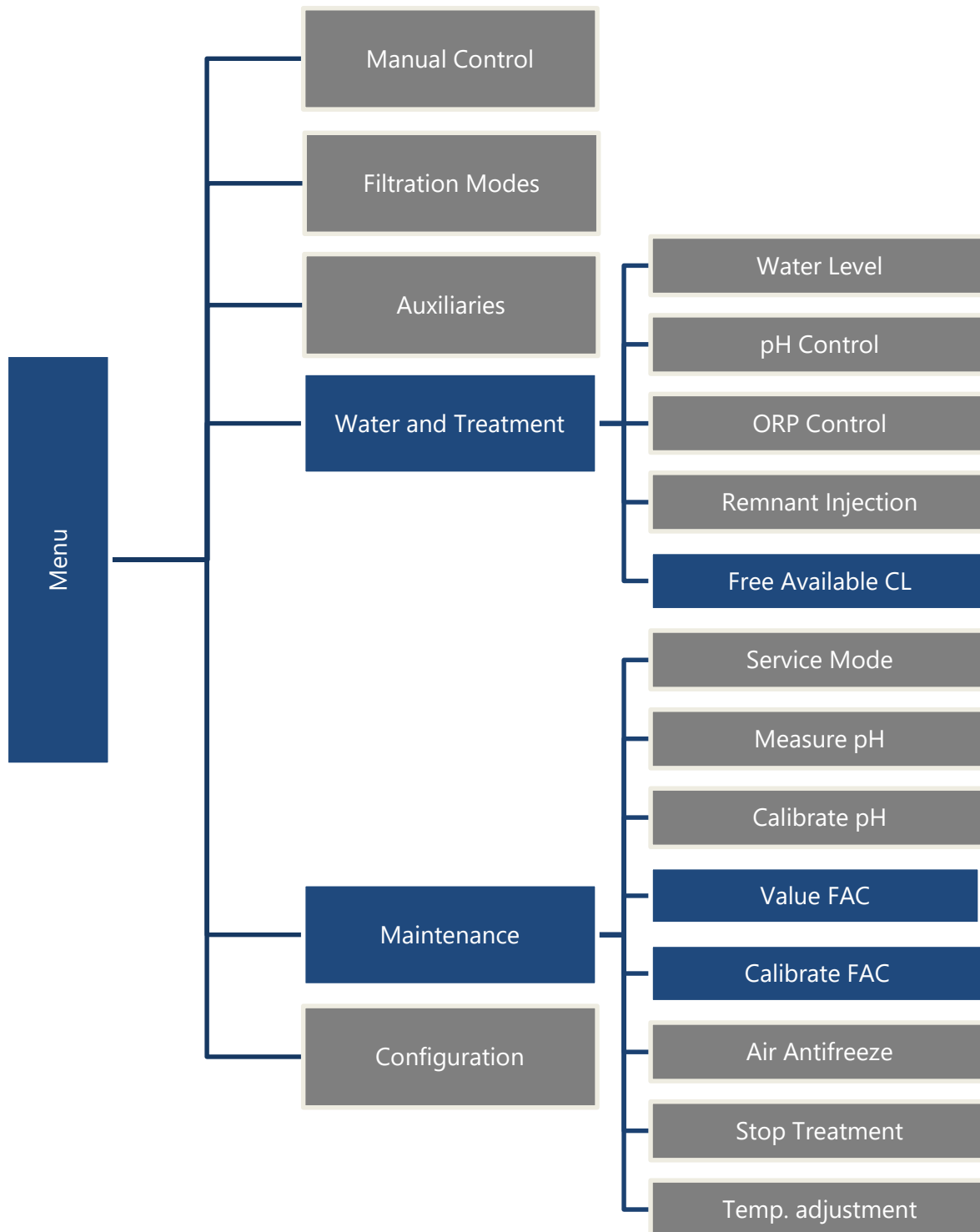

### 4.1.1 Water and Treatment



**Status:** Current status of the Chlorine Sensor  
**Value:** Current measured Chlorine in PPM  
**Low alert:** Set and adjust the value in PPM below which the Low Alert is active  
**High Alert:** Set and adjust the value in PPM above which the High Alert is active  
**Protection:** Set to YES if sensor is used to limit chlorine levels.

### 4.1.2 Maintenance

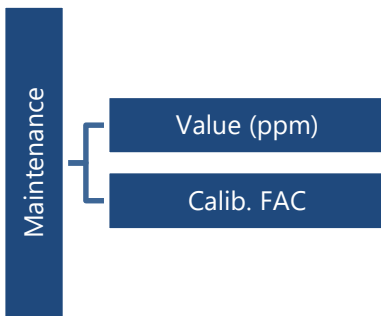

**Value (ppm):** Current measured FAC in ppm.  
**Calibrate FAC:** Enter a value to calibrate the Chlorine Sensor (see 3.9).

## 4.2 VIEW THE DISPLAY OF FAC

Display of last measured FAC in ppm is available in the following menus:

- FAC Data** Menu – value displayed in ppm.

FAC DATA	
<b>Installed</b>	: YES
<b>Status</b>	: OK
> <b>Value (ppm)</b>	: 3.15
<b>Low Alert</b>	: 03.0ppm
<b>High Alert</b>	: 10.0ppm
SELECT      QUIT	

- Maintenance Menu
  - Value display in ppm
  - Pressing SELECT updates the value.
  - Calibration factor is displayed.

MAINTENANCE	
<b>Service Mod</b>	: NO
<b>Mesure pH</b>	: 7.5
<b>Calib pH.</b>	: -0.02
> <b>Value FAC</b>	: 3.50
<b>Air Antifrz</b>	: - 5.0°C
SELECT      QUIT	

## 4.3 CHLORINE SENSOR CALIBRATION

The Chlorine Sensor must be calibrated at least once every 7 days, or as required by the local, state, province or national health department.

### 4.3.1 Water Sample for Calibration



#### CAUTION

**Always comply with local, county, state, and country code and regulations for water testing and sampling.**



#### NOTE:

**If the water sample temperature used to test pH and chlorine to calibrate the sensor exceeds 32°C (90°F) it is recommended to cool the sample prior to testing. Ensure the sample bottle remains closed during cooling. Cooling can be aided by running the sample bottle under colder water.**

Water sample must be taken within 10 minutes prior to calibration:

- It is not recommended to carry out a Chlorine calibration within 24 hours of any manual chemical additions.
- Ensure that the Chlorine Sensor has been conditioned for at least 12 hours preferably 24 hours prior to carrying out calibration.
- Ensure that there are no air bubbles in the tubes or Flow Cell.
- Ensure that the flow rate is stable in the acceptable range.
- Ensure that the water sample is correctly mixed and that it is representative of the water body.
- Sample from the inline sample port, or from a suitable location in the water body if not possible.
- Measure the water sample parameters with an NSF 50 Level 1 device (such as LaMotte Spin Touch, using the single use disk 4329) or other approved photometer, or NSF 50 certified or approved DPD test equipment.
- Ensure that all Acceptable Parameters are respected.

### 4.3.2 Water Sample Location



#### CAUTION

**Always comply with local, county, state, and country code and regulations for water testing and sampling.**

#### 4.3.2.1 Inline Sample Port

The water sample for calibration is taken from the inline sample port on the sensor panel as this is the water that passes across the sensor.



#### NOTE:

**Health inspectors will sample water from the water body itself, not the inline sample port. Ensure that water from the inline sample port is representative of the bulk of the water body.**



#### CAUTION

**Proper hydraulic circulation assures that the water sample taken from the inline sample port is representative of the bulk water in the water body. Inadequate circulation and water mixing can result in risk to bather safety.**

#### 4.3.2.2 Bulk Water Validation

To ensure that sample water accurately represents the bulk water, the following parallel bulk water validation is recommended:

- Prior to initial sensor calibration; and
- Once per month or more if required by code or regulations.

Bulk Water Validation Procedures:

- General guidelines:
  - Measurement of pH and Chlorine can be done using any approved or certified test method.
  - Each measurement from sample locations will be tabulated for comparison.
  - The maximum deviation from the inline sample port for each location is:
    - Chlorine  $\pm 1.0$  ppm and within acceptable limits
    - pH  $\pm 0.3$  and within acceptable limits
  - All samples shall be obtained from a location with the following qualities:
    - At least 45.7 cm (18") below the surface of the water; and

- A water depth of between 90-120cm (3-4 feet) when possible; and
- A location between water return inlets; and
- Sampling locations shall:
  - Rotate around the shallow end; and
  - Includes a sample from the deepest end.
- ☐ number of samples to be taken:
  - Regular shaped water bodies:
    - Small water bodies up to 30m<sup>3</sup> (8,000 USG) 2
    - Medium water bodies of 30m<sup>3</sup> to 190m<sup>3</sup> (8,000 to 50,000 USG) 3
    - Large water bodies of over 190m<sup>3</sup> (50,000 USG) 4, and at least each corner
  - Irregular shaped water bodies:
    - AS per above for water volume
    - Additional locations to ensure that the water samples are representative of the entire water body.

If the periodic parallel validation shows that inline sample port water is not properly representative of the bulk water, investigate further and properly correct the circulation and bulk water mixing and then again.

### 4.3.3 Calibration Procedure

The sensor must be conditioned for at least 12 hours preferably 24 hours with flow ON prior to calibration.

- ☐ Ensure that the filtration pump is ON.
- ☐ Ensure that flow and all other parameters are acceptable.
- ☐ Select the **MAINTENANCE** menu.

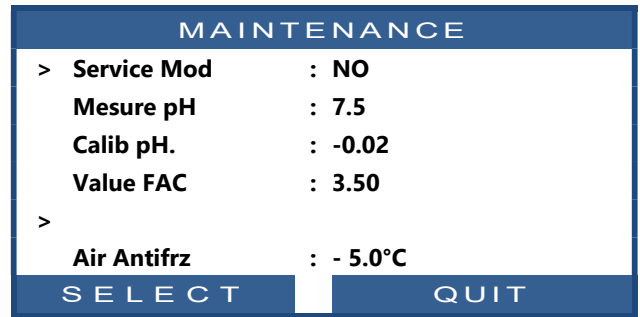

- ☐ Select Calib. FAC from the MAINTENANCE Menu

- ☐ Enter the DPD1 ppm value measured in the sample water:
  - Enter FAC to two digits after the decimal.
  - If manual measurement is only available to one digit after the decimal, this is acceptable though less accurate.
- ☐ Confirm correct value then press SELECT, to start calibration.
- ☐ Calibration can take up to 60 seconds

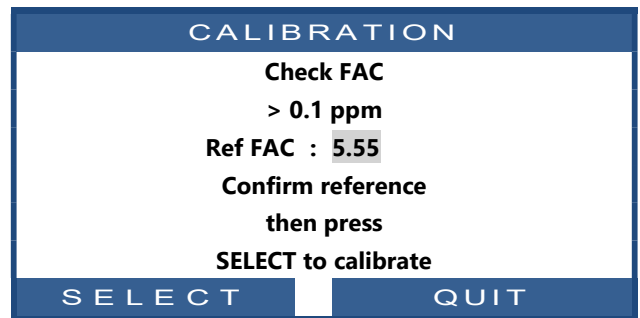

**NOTE:**

**During the calibration process, PoolCOP compares the "offset" of the probe to the signal that would be delivered by a perfect probe. This offset is essentially related to wearing.**

**If the offset is too large, calibration is not possible.**

**It is then necessary to check that the reference Chlorine is correct. If this is the case, the probe must be reconditioned or replaced.**

Provided installed and maintained correctly, if the sensor cannot be calibrated successfully, or an error message is displayed, see Troubleshooting.

## 4.4 VIEW AND RESET ALERTS

If an alert is active, the **ALERT** button will flash, the number of active alerts is displayed in brackets.

Pressing the **ALERT** button will display the alert.

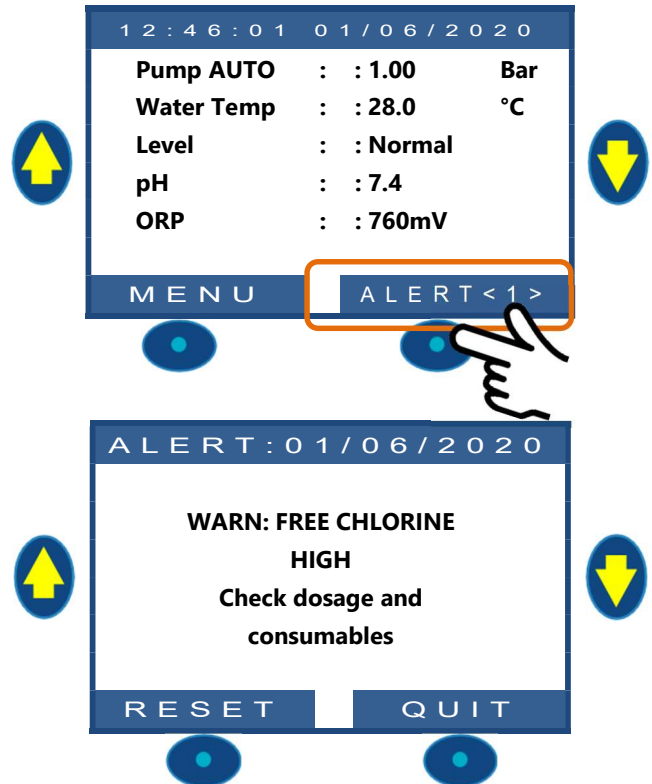

If there are multiple alerts, using the **UP** and **DOWN** arrows scrolls through the alert messages.

**CHLORINE HIGH** and **CHLORINE LOW** alerts cannot be reset manually.

When the condition is corrected, the alert will reset automatically.

## Section 5 PROGRAMMING GUIDE

Error! Bookmark not defined.

### 5.1 CHLORINE SENSOR CONFIGURATION

Chlorine Sensor configuration is required to start data exchange.

To proceed, go to the Water and Treatment, Free Available CL menu:

Chlorine DATA	
> Installed	: YES
Status	: OK
Value (ppm)	: 3.50
Low Alert	: 03.0ppm
Protection	: NO
SELECT	QUIT

This menu allows installation and configuration of the Chlorine Sensor

#### 5.1.1 Installed

If **INSTALLED: YES**, PoolCop will read chlorine value every 10 seconds.

If set to **NO**, reading is deactivated.

**Text:** Installed  
**Default:** NO  
**Entries:** YES;  
 NO

#### 5.1.2 Status

Current status of the sensor:

- OK:** Chlorine Sensor is responding and returning chlorine value.
- ABSENT:** Check wiring connections.
- ERROR:** Chlorine Sensor returns an error. Check wiring and sensor condition.

**Text:** Status  
**Default:** Read only

#### 5.1.3 Value

Display the latest chlorine value in ppm, and updated every 30 seconds.

**Text:** Value  
**Default:** Read only

#### 5.1.4 Setting Low Alert

Allows to define the value to trigger low alert message.

The alert is only issued if the measurement remains below the threshold for more than 10 minutes.

Cannot be higher than "High Alert".

**Text:** Low Alert  
**Default:** 3.0 ppm  
**Entries:** 0.0 - 5.0 ppm

#### 5.1.5 Setting High Alert

Allows to define the value to trigger high alert message.

The alert is only issued if the measurement remains above the threshold for more than 10 minutes.

Cannot be lower than "Low Alert".

**Text:** High Alert  
**Default:** 10.0 ppm  
**Entries:** 0.5 - 25.0 ppm

#### 5.1.6 Protection

If **PROTECTION: YES**, PoolCop will act on the disinfectant dosage to maintain the chlorine level between the low and high alerts. **This only if ORP control is installed and the disinfectant type is different from « read-only ».** (see ORP Control menu)

If set to **NO**, the chlorine value is only indicative and does not affect disinfection.

**Text:** Protection  
**Default:** NO  
**Entries:** YES;  
 NO

## Section 6 TROUBLESHOOTING AND MAINTENANCE



### WARNING

Make sure to wear rubber gloves and protective eye wear when servicing the Chlorine Sensor because the Electrolyte is a strong acid.



### NOTE:

Electrolyte is safe to be diluted and can be safely poured down the drain.



### NOTE:

Electrolyte shelf life is one year from date of manufacture (see date on the bottle).



### CAUTION

Do not touch the cathode during this process since it can be damaged.

## 6.1 TROUBLESHOOTING

### 6.1.1 Symptoms, Cause, Remedy

Symptom	Possible Cause	Solution/Remedy
<b>Water not flowing adequately through the flow chamber</b>	<i>Incorrect flow adjustment</i>	<i>Adjust flow control knob so that the flow indicator lines up with the mark on the flow chamber</i>
	<i>Filter cartridge blocked with debris</i>	<i>Clean or replace the cartridge</i>
	<i>Air locks or debris in the panel channels.</i>	<i>Adjust the flow up and down or slowly remove the plugs to clear blockages</i>
	<i>Not enough differential pressure</i>	<i>Check locations from which INLET water is taken and OUTLET water is returned</i>
<b>Sensor cannot be calibrated and measured value greater than DPD measurement</b>	<i>Conditioning period too short</i>	<i>Observe the correct full conditioning period</i>
	<i>Membrane Cap damaged</i>	<i>Replace Membrane Cap</i>
	<i>Troublesome substances in the water</i>	<i>Check water for troublesome substances and remedy this</i>
	<i>Short circuit in the measuring line</i>	<i>Identify short circuit and eliminate the cause</i>
	<i>Distance between membrane/electrode is too great</i>	<i>Screw the Membrane Cap up to its stop</i>
	<i>DPD chemicals out of date</i>	<i>User new chemicals, repeat calibration</i>
	<i>pH value &lt; pH 5.5</i>	<i>Increase pH value (pH 7.2 - 7.8)</i>
<b>Sensor cannot be calibrated, and sensor measured value less than DPD measurement</b>	<i>Check whether the reference electrode at the end of the electrode shaft is silvery-white instead of brownish grey color.</i>	<i>The reference electrode is then worn out and needs to be replaced. See Repairing a Damaged Sensor.</i>
	<i>Conditioning period too short</i>	<i>Observe the correct full conditioning period</i>
	<i>Coating on the Membrane Cap</i>	<i>Replace Membrane Cap, ensure sensor conditioning and then calibrate</i>
	<i>Sample water flow rate too low</i>	<i>Adjust flow control knob so that the flow indicator lines up with the mark on the flow chamber</i>
	<i>Air bubbles on the outside of the membrane</i>	<i>Increase the flow within the permitted range</i>

	<i>pH value &gt; pH 9.5</i>	<i>Lower pH value (pH 5.5 ... 9.5)</i>
	<i>No Electrolyte Gel in the Membrane Cap</i>	<i>Fill with new Electrolyte Gel</i>
	<i>Electrolyte pushed out by gas bubbles in the sample water</i>	<i>?</i>
	<i>Check whether the reference electrode at the end of the electrode shaft is silvery-white instead of brownish grey color.</i>	<i>The reference electrode is then worn out and needs to be replaced. See Repairing a Damaged Sensor.</i>
<b>Measured value display is '0'</b>	<i>Chlorine content below the lower limit of the measuring range</i>	<i>Add chlorine and then repeat calibration and/or use a suitable sensor</i>
	<i>Measuring line broken</i>	<i>Replace measuring line</i>
	<i>Sensor connected to the controller with incorrect polarity</i>	<i>Connect the sensor correctly to the controller</i>
	<i>Conditioning period too short</i>	<i>Observe the conditioning period</i>
	<i>Sensor defective</i>	<i>Send sensor in for regeneration</i>
	<i>Check whether the reference electrode at the end of the electrode shaft is silvery-white instead of brownish grey color.</i>	<i>The reference electrode is then worn out and needs to be replaced. See Repairing a Damaged Sensor.</i>
<b>Sensor measured value is unstable</b>	<i>Membrane damaged</i>	<i>Replace Membrane Cap, ensure sensor conditioning and then calibrate</i>
	<i>Air bubbles on the outside of the membrane</i>	<i>Remove air bubbles by tapping them and increase flow rate if necessary</i>
	<i>Reason lies with the controller</i>	<i>Eliminate cause</i>
	<i>Check whether the reference electrode at the end of the electrode shaft is silvery-white instead of brownish grey color.</i>	<i>The reference electrode is then worn out and needs to be replaced. See Repairing a Damaged Sensor.</i>



## 6.1.2 Troubleshooting Sensor LED Lights

Ignore the LED flash codes for approximately 120 seconds after powering the chlorine sensor.

### 6.1.2.1 Left LED Light: Device, Sensor Indicator

COLOR	Flash Code	Cause	Result	Remedy
GREEN	Illuminated	No defect present	Standard operation	None required
NONE	-	No supply voltage	Sensor not functioning	Check cable connections
RED	Illuminated	Electronics error	Sensor faulty	Return chlorine sensor or contact PCFR
RED	Flashing *	Start-up phase	No measuring value communication	Wait briefly
RED	Slowly flashing **	Calibration incorrect	Measuring value incorrect	Re-calibrate
RED	Double flashing ***	0 ppm > measuring value > 10 ppm	Measuring value too high / too low	Check chlorine content of sample water
		Measuring value = limit value	Violation of limit value	Clarify cause; if required, re-set values
		No correction value pH transmitted	Correction value pH missing	Check parameters and configuration. Check pH sensor
"Flash Codes" for the table above. 				

### 6.1.2.2 Right LED: Modbus, Communication Indicator

COLOR	Flash Code	Cause	Result	Remedy
GREEN	Illuminated	Bus operational	Standard operation	N/A
GREEN	Flashing *	Bus preoperational	Presently no measuring value communication	Wait briefly
RED	Arbitrary	Bus error	No measuring value communication	Contact PCFR
"Flash Codes" for the table above. 				

## 6.1.3 Repairing a Damaged Sensor

The sensor can only be repaired in the factory. Return it to PCFR in original packaging for repair.

## 6.2 PREFILTER CLEANING AND MAINTENANCE

Cleaning and maintenance, including replacement of the filter cartridge, is on requirement.

### 6.2.1 Clean the Prefilter and Prefilter Cartridge when:

- Visible debris present.
- Flow rate is low or cannot be maintained (Flow Indicator not reaching the Flow Mark)

### 6.2.2 Replace the Prefilter Cartridge if:

- Cartridge is damaged or worn.
- Debris can be seen in any of the channels after the prefilter, the flow control chamber, or the sensor chamber.
- It is recommended to replace the cartridge after 12 months.

### 6.2.3 Cleaning the Prefilter

- Completely close the isolation valve supplying water to the panel, or alternatively stop the filtration.
- Open the water sample tap to discharge any pressure or suction.
- Dismantle the prefilter as follows:

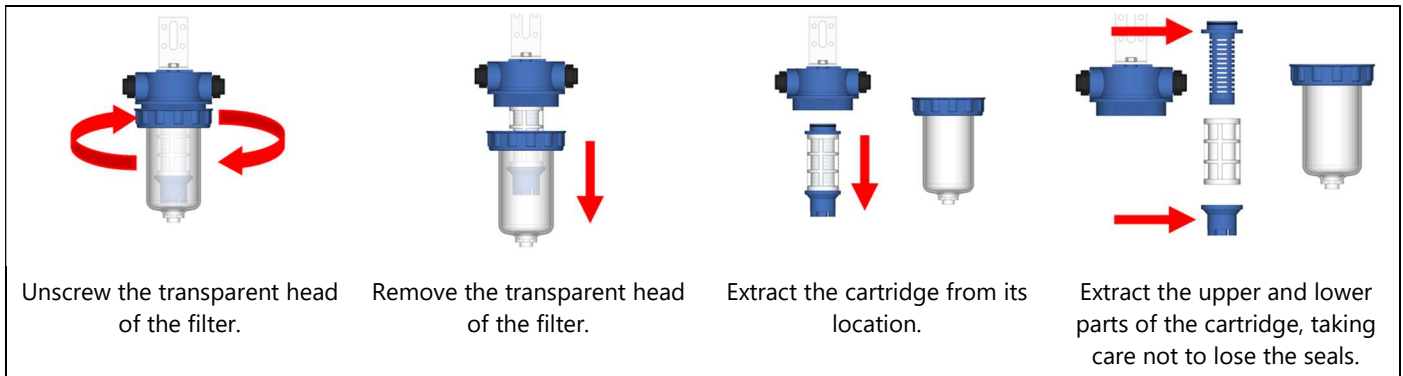

- Clean the cartridge under clean water taking care not to damage the cartridge element.
- Reassemble the prefilter as follows:

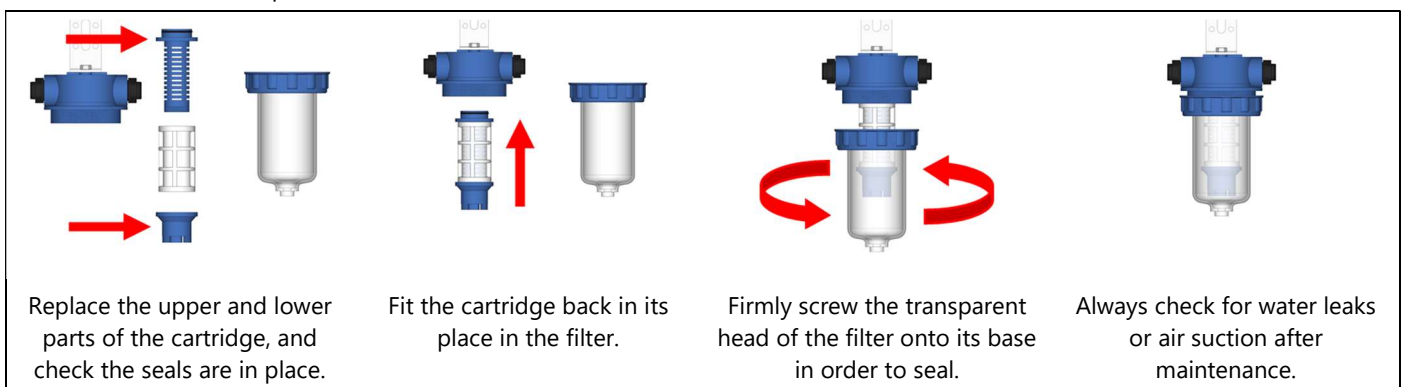

- Close the inline sample port tap.
- Open the isolation valve or restart the filtration as needed.
- Check for leaks and air bubbles.
- Check flow by taking a sample from the inline sample port.
- Adjust flow control to ensure adequate flow (Flow Indicator aligned with the Flow Mark).

## 6.3 CHLORINE SENSOR MAINTENANCE

### 6.3.1 Removing the Sensor from the Sensor Chamber



#### WARNING

When winterizing or decommissioning the sensor observe all safety information. Dispose of the Electrolyte Gel in accordance with the Electrolyte Gel's safety data sheet.

#### NOTE

The following videos show clearly how to fill the Electrolyte and clean the sensor.

Changing Electrolyte Gel in English

- [www.youtube.com/watch?v=0Oa2gkciqdo](http://www.youtube.com/watch?v=0Oa2gkciqdo)
- [www.youtube.com/watch?v=nUy1BNCqBrE](http://www.youtube.com/watch?v=nUy1BNCqBrE)

Changement de membrane en français :

- [www.youtube.com/watch?v=27H-Q3Mw4Y&t=40s](http://www.youtube.com/watch?v=27H-Q3Mw4Y&t=40s)

This procedure is applicable for a technical shutdown, for the winterization of the sensor or for an extended shutdown of chlorine measurement features:

- Switch off the CCU/DCCU.
- Completely close isolation valves on the tubes supplying water to the chlorine sensor panel INLET and OUTLET. Alternatively close any manual valves to stop flow to the panel.
- Open the inline sample port to release any pressure and allow water to drain from the flow cell.
- Unscrew the compression nut and remove the chlorine sensor from the sensor chamber in the flow cell.

- Unscrew the Membrane Cap.
- Dispose of the Membrane Cap properly. Do not reuse under any circumstances.

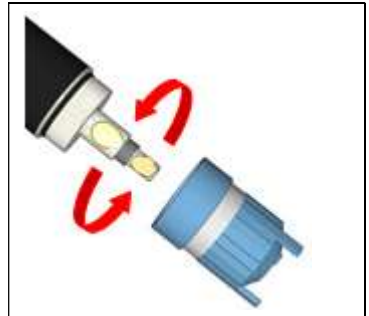

- Rinse the end of the sensor with clean non-chlorinated water.
- Very gently removing the any excess electrolyte with the tip your finger.
- Do not rub the end of the sensor with any tool or fabric as this will damage the electrode surfaces.



- Gently dab and soak up any remaining water and electrolyte using non-abrasive absorbent paper.



#### CAUTION

**Use only non-abrasive paper to avoid abrading or damaging the electrodes. Incorrectly carried out this will can lead to the damage or destruction of the measuring electrodes.**

### 6.3.2 Membrane Cap and Electrolyte Gel Replacement

Replace the Membrane Cap and Electrolyte Gel:

- Every six (6) months; or
- When calibration cannot be maintained; or
- When reinstalling after storage, as per Section 7.

See 3.5.2: Chlorine Sensor Assembly and Preparation

### 6.3.3 Refitting the Sensor into the Sensor Chamber in the Flow Panel

See 3.5.3: Install the Sensor in the Sensor Chamber in the Flow Panel

## Section 7 STORAGE, DECOMMISSIONING AND DISPOSAL

### 7.1 WINTERIZATION AND STORAGE

#### 7.1.1 When Chlorine Sensor is Switched OFF or Out of Commission

- Short Term Storage (one week or less):
  - Store in Flow Panel with tap drinking water to prevent the sensor from drying out.
- Intermediate Term (one week to one month):
  - Store with Membrane Cap on the sensor in a beaker with tap drinking water to keep membrane wet.
- Long Term (more than one month):
  - See Winterization or Decommissioning below.
- Other Conditions:
  - When out of commission, store sensor according to recommendations below.

#### 7.1.2 Winterization or Decommissioning

See 6.3.1 for sensor removal.

#### 7.1.3 Recommissioning

After long term decommissioning:

- Sensor must be reconditioned as per §3.5.2 and §3.5.3.
- Run the Chlorine Sensor under flow and powered for at least 12 hours preferably 24 hours before calibration.

#### 7.1.4 Storage Conditions

Keep the packaging including the polystyrene inserts. Only store the sensor in its original packaging.

- |   |  |
|---|--|
| <input type="checkbox"/> Permissible ambient temperature:                       | +5°C to +50°C                          |
| <input type="checkbox"/> Maximum relative air humidity:                         | 90% non-condensing                     |
| <input type="checkbox"/> Other storage conditions:                              | no dust or direct sunlight             |
| <input type="checkbox"/> Electrolyte Gel in original packaging, maximum period: | see label on the bottle                |
| <input type="checkbox"/> Chlorine Sensor in original packaging, maximum period: | 3 years, standard atmospheric pressure |

If the sensor is stored for a long period of time, return it to PCFR for checking or servicing to ensure measuring accuracy of the sensor.

### 7.2 DISPOSAL



#### NOTE:

**PCFR will take back decontaminated used devices for disposal provided that return shipping is fully paid.**







#### CAUTION

**Note the current regulations and legal standards which apply in your region or country. Respect all regulations governing disposal of used parts and consumables.**

## Section 8 SPARE PARTS AND DIAGRAMS

### 8.1 RECOMMENDED INSTALLATION ACCESSORIES (NOT SUPPLIED)

 <p>3/8" OD firm polyethylene tubing for drinking water semi clear white</p>	 <p>3/8" NPTF Tap Tool</p>	 <p>PTFE Thread Tape</p>	 <p>3/8" Plastic Tube Clip</p>
---	---	--	---

### 8.2 OPTIONAL INSTALLATION ACCESSORIES

 <p>PVC Saddle, example PVC Saddle of suitable size, with 3/8" NPTF female thread</p>			
--	--	--	--

### 8.3 SPARE PARTS LIST

Part Number	Contents	QTY
<b>AC5300</b>	<b>PoolCop Chlorine Sensor FAC Installation Pack NA</b> , contains the references below:	
AC5310	1. PoolCop Chlorine Sensor FAC	1
AC5330	2. PoolCop Chlorine Sensor Cable	1
AC1003	3. PoolCop Modbus Adaptor	1
AC5320	4. PoolCop Chlorine Sensor Flow Panel NA	1
AC5340	5. PoolCop Chlorine Sensor Maintenance Kit	1
AC5380	6. isolation valves, 3/8" tube compression connectors with 3/8" NPTF male thread.	1
<b>AC5340</b>	<b>PoolCop Chlorine Sensor Maintenance Kit</b> , contains the references below:	
-	1. Membrane Cap, with transport cap	2
-	2. Electrolyte Gel, 50mL bottle and nozzle	1
<b>AC5360</b>	<b>PoolCop Chlorine Sensor Replacement Prefilter Cartridge</b>	1

#### 8.3.1 PoolCop Chlorine Sensor FAC

<p>□ AC5310</p>	
-----------------	--

### 8.3.2 PoolCOP Chlorine Sensor Cable

□ AC5330



### 8.3.3 PoolCOP Modbus Adaptor

□ AC1003



### 8.3.4 PoolCOP Chlorine Sensor Flow Panel NA

- AC5320:
- 1 x SUPPLY connector for 3/8" Tube with 3/8" NPTF Male Thread
  - Prefilter, with
    - INLET connector for 3/8" Tube
    - Cartridge
  - Prefilter to Flow Cell Connector and Tube Set
  - Flow Cell with:
    - Flow Control Knob
    - Flow Chamber
    - Water Sample Tap
    - Sensor Chamber
    - OUTLET connector for 3/8" Tube
  - 1 X RETURN connector for 3/8" Tube with 3/8" NPTF Male Thread, with isolation valve.
  - 2 x isolation valves, 3/8" tube compression connectors with 3/8" NPTF male thread.

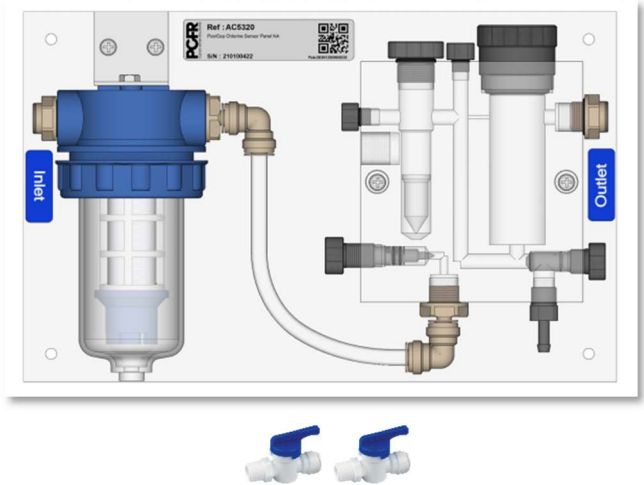

### 8.3.5 PoolCop Chlorine Sensor Maintenance Kit

- AC5340:
  - 2 x Membrane Cap, with transport cap
  - 1 x Electrolyte Gel, 50mL bottle and nozzle



### 8.3.6 Isolation valve, 3/8"

- AC5380: isolation valve, 3/8" tube compression connectors with 3/8" NPTF male thread.



## Section 9 TECHNICAL SPECIFICATIONS

### Components

#### PoolCop Chlorine Sensor FAC Installation Kit NA

PoolCop Chlorine Sensor FAC	1
PoolCop Chlorine Sensor Cable	1
PoolCop Modbus Adapter	1
PoolCop Chlorine Sensor Panel	1
Electrolyte	1
Membrane Cap	2
isolation valve	2

### Technical Specifications

Measuring principle, technology	Amperometric, 2 electrodes, membrane-covered
Reference method	DPD1
Resistance to:	Surfactants, cyanuric acid
Selectivity	Total available chlorine and free chlorine as against combined chlorine (chloramines)
Disinfection process	Disinfectants with organic chlorine, e.g., based on cyanuric acid, chlorine gas, hypochlorite, electrolysis
Dimensions	221mm x 25mm diameter
Cable	5 meters, 4-conductor shielded, with connector and wire leads with 0.5mm ferrules
Power Supply	12 VDC from PoolCop, 60 mA maximum
Communication Standard, Protocol	RS485 Modbus RTU
Baud Rate	9600
Measurement Range	0 – 10 PPM FAC
pH Range	5.5 – 9.5
Temperature Range	5 – 45°C (41 - 113°F)
Pressure	1 bar (14.55 psi)
Flow Rate	30 – 60 Lph (0.13 - 0.26 gpm)
Cross-Sensitivity	ClO <sub>2</sub> , ozone, bromine, iodine
Chemical Compatibility	up to 50% ethanol/water or up to 50% glycerol/water
Conformity	NSF 50, UL, CE



**PoolCop**  
Always. Better. Blue.